

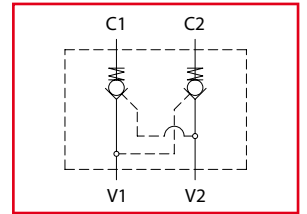

# VRDP

Valvole di blocco a doppio effetto  
Double acting pilot check valves



Dati tecnici Technical data	
Viscosità fluido Fluid viscosity	10-500 mm <sup>2</sup> /s 45 to 2000 ssu (6 to 420 cSt)
Classe di contaminazione Filtration	ISO code 16/13 SAE class 4 or better
Temperatura fluido Fluid temperature	-20°C +80°C -4°F +176°F
Temperatura ambiente Ambient temperature	-20°C +50°C -4°F +122°F

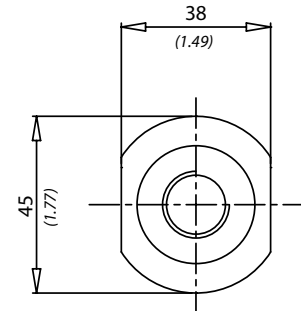
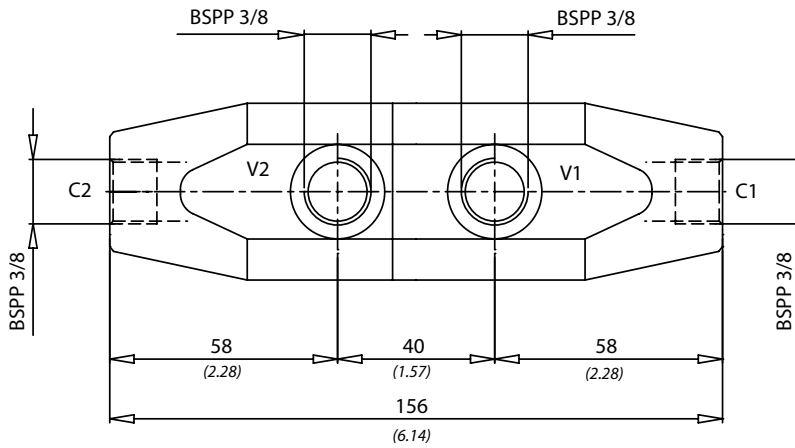
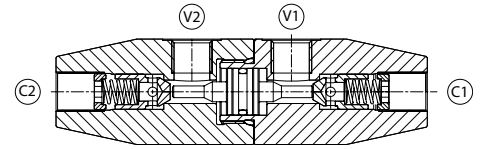

mm  
(Inches)

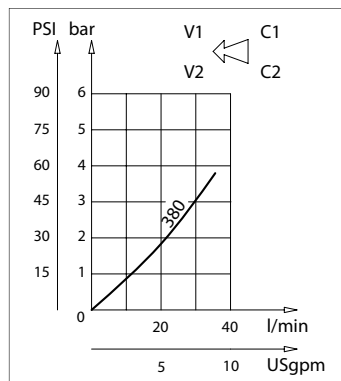
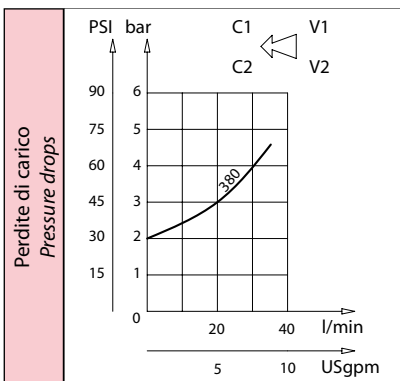

Caratteristiche tecniche Technical performances				
Codice Code	Portata Max Max flow l/min - USgpm	Pressione Max Max pressure bar/PSI	Peso approssimativo Approx weight Kg / lb	Rapporto di pilotaggio Pilot ratio
<b>VRDP 380</b>	<b>35 (9)</b>	<b>320 (4500)</b>	<b>1,42 (3.15)</b>	<b>1:4</b>

Codice ordinazione Ordering code
<b>VRDP-380</b>