

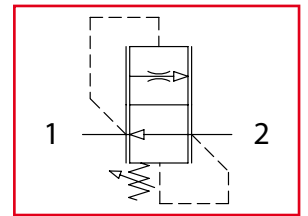

VRD

Valvole controllo discesa compensate regolabili
Adjustable compensated flow control valves



Dati tecnici Technical data	
Viscosità fluido Fluid viscosity	10-500 mm ² /s 45 to 2000 ssu (6 to 420 cSt)
Classe di contaminazione Filtration	ISO code 16/13 SAE class 4 or better
Temperatura fluido Fluid temperature	-20°C +80°C -4°F +176°F
Temperatura ambiente Ambient temperature	-20°C +50°C -4°F +122°F

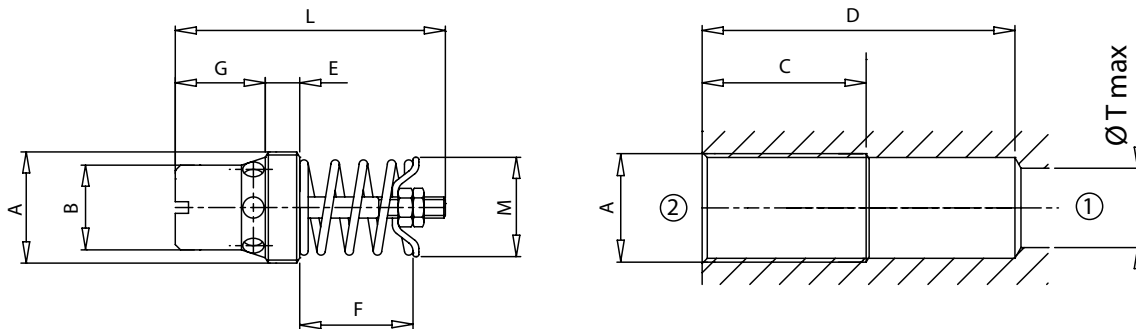
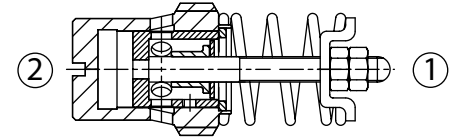

mm
(Inches)

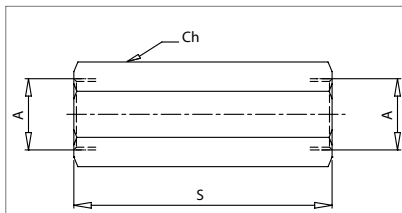

Colonna / Housings M/F

Dimensioni / Dimensions

Codice Code	A	Peso / Weight Kg / lb
61100051	BSPP 1/4	0,11 (0.16)
61100052	BSPP 3/8	0,12 (0.20)
61100053	BSPP 1/2	0,20 (0.33)
61100054	BSPP 3/4	0,29 (0.50)

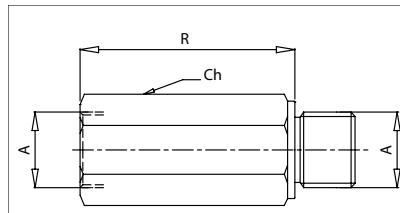

Colonna / Housings F/F

Dimensioni / Dimensions

Codice Code	A	Peso / Weight Kg / lb
61100057	BSPP 1/4	0,11 (0.16)
61100058	BSPP 3/8	0,14 (0.20)
61100059	BSPP 1/2	0,24 (0.30)
61100060	BSPP 3/4	0,34 (0.48)

Caratteristiche tecniche Technical performances

Codice Code	A	Portata Max Max flow l/min - USgpm	Pressione Max Max pressure bar/PSI	B	C	D	E	T	G	L	M	R	S	Ch	Peso approssimativo Approx weight Kg / lb
VRD140	BSPP 1/4	20 (5.3)	300 (4350)	10 (0.39)	33 (1.30)	53 (2.09)	6 (0.24)	7 (0.28)	13,5 (0.53)	39 (1.54)	10 (0.39)	57 (2.24)	66 (2.60)	19 (0.75)	0,013 (0.029)
VRD380	BSPP 3/8	35 (9.2)		12,5 (0.49)	36 (1.42)	60 (2.63)	5 (0.20)	9,5 (0.37)	15,5 (0.61)	45 (1.77)	14 (0.55)	64 (2.52)	73 (2.87)	22 (0.87)	0,024 (0.053)
VRD120	BSPP 1/2	65 (17.1)		16 (0.63)	39 (1.54)	63 (2.48)	7 (0.28)	12 (0.47)	16 (0.63)	51 (2.01)	18 (0.71)	69 (2.72)	81 (3.19)	27 (1.06)	0,037 (0.082)
VRD340	BSPP 3/4	150 (40)		20 (0.79)	50 (1.97)	81 (3.19)	10 (0.39)	16 (0.63)	21 (0.83)	62 (2.44)	23 (0.91)	87 (3.43)	99 (3.90)	32 (1.26)	0,077 (0.17)



VRD

Valvole controllo discesa compensate regolabili
Adjustable compensated flow control valves

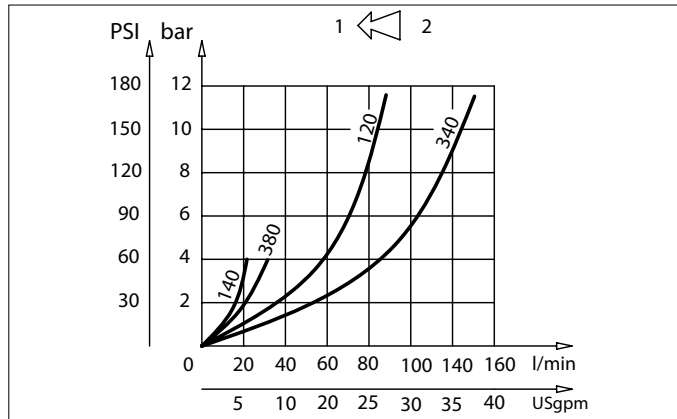
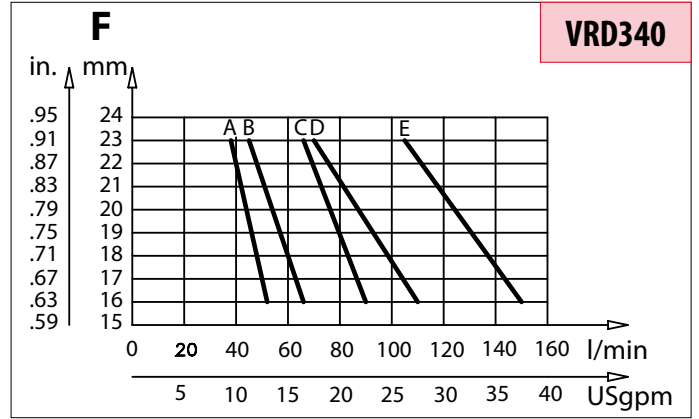
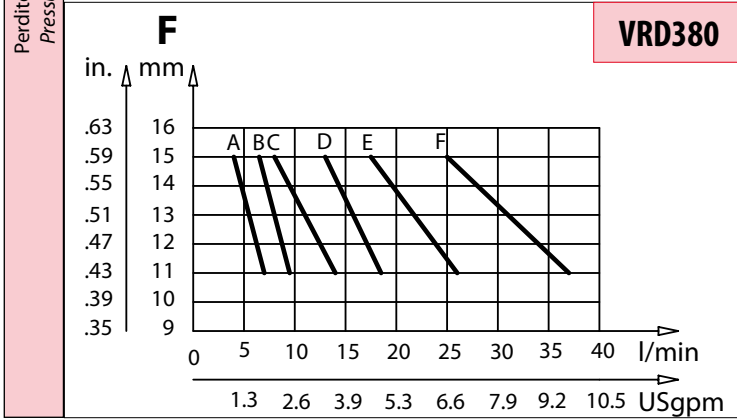
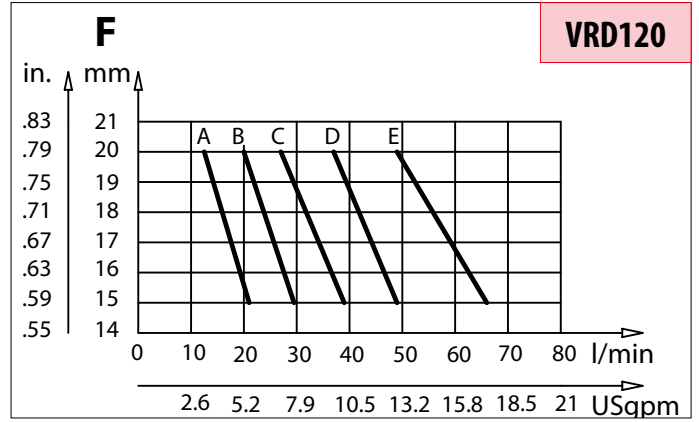
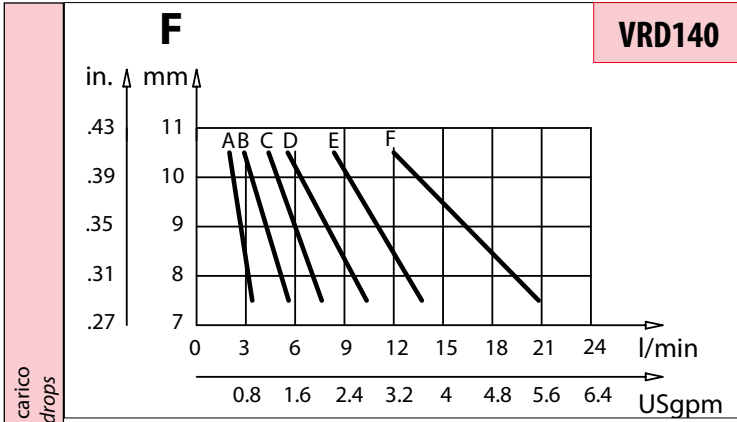
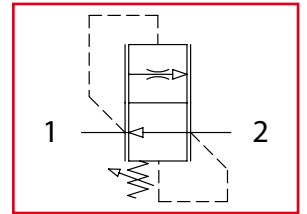

Codice ordinazione
Ordering code

VRD - X - Y - K

X	Dimensione / Size	Campo di regolazione Flow Range	Y	Portata controllata a 50 bar ± 0,10 l/min Controlled flow at 50 bar ± 0.10 USgpm						K	Regolazione / Setting
				A	B	C	D	E	F		
140	BSPP 1/4	VRD140	VRD140	0,8/7 (0.2/1.9)	1,5/9,5 (0.4/2.5)	2,3/14 (0.6/3.7)	4/18,5 (1/4.9)	6/26 (1.6/6.8)	8/37 (2.1/9.7)	F	Esempio: regolazione 15 mm Example: setting 15 mm F15
380	BSPP 3/8		VRD380	4/7 (1/1.9)	6,5/9,5 (1.7/2.5)	8/14 (2.1/3.7)	13/18,5 (3.4/4.9)	17,5/26 (4.6/6.8)	25/37 (6.6/9.7)		Omettere se non richiesto Omit if not required
120	BSPP 1/2		VRD120	12,5/21 (3.3/5.5)	20/29,5 (5.3/7.8)	27/39 (7.1/10.3)	37/49 (9.7/12.9)	49/66 (12.9/17.4)	-		
340	BSPP 3/4		VRD340	38/52 (10/13.7)	45/66 (12/17.4)	66/90 (17.4/23.8)	70/110 (18.5/29)	115/150 (30/40)	-		